

# 40SI™ Heavy Duty Brushless Alternator

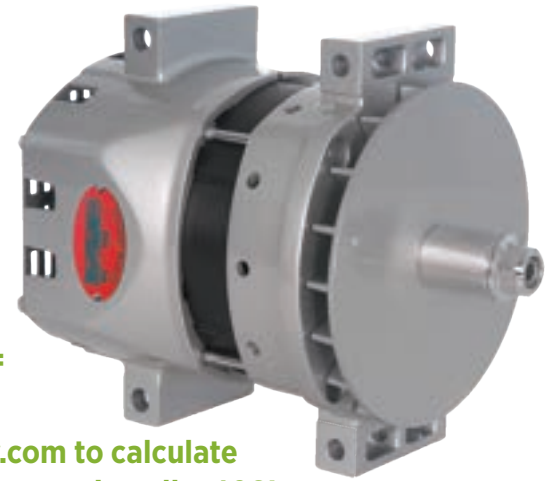

## FEATURES & BENEFITS

- **Brushless Advantage:** fewer moving parts means less wear and longer life
- **Equipped with Remote Sense** which can reduce battery charge time by 50%

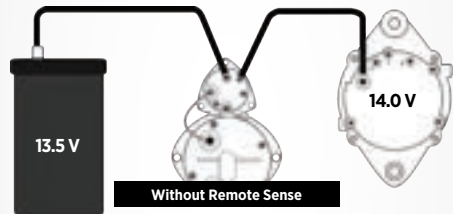

Remote Sense utilizes a second wire that reads the actual voltage at the battery. This signals the alternator to boost its output to compensate for the voltage drop, ensuring 14 Volts at the battery. The proper voltage forces more current into the battery bringing it to a full state of charge between vehicle stops.

- **OE approved**, assuring OE quality and performance for aftermarket replacements
- **Superior output** producing up to 320 Amps at road speed and 190 Amps at idle
- **Warranty:** 3 year/unlimited miles (Applicable to U.S. and Canada only)

## High Efficiency = Fuel Economy

Go to [delcoremy.com](http://delcoremy.com) to calculate your savings when you install a 40SI.

**High efficiency translates to less engine horsepower requirements, resulting in substantial fuel savings.**

Real time operating data was collected on several vehicle applications for the overall vehicle and electrical system. The following chart shows the fuel cost savings over a typical life cycle by increasing the alternator efficiency from 60% to 72%.

## FUEL SAVINGS

Vehicle Type & Miles Driven	Average Current	Fuel Cost with a 60% Efficient Alternator	Fuel Cost with a 72% Efficient Alternator (40SI)	Savings
Line Haul Tractor (500k mi)	84 Amps	\$4,534	\$3,778	\$756
City Tractor (350k mi)	40 Amps	\$2,235	\$1,863	\$372
School Bus (250k mi)	102 Amps	\$9,040	\$7,533	\$1,057

Based on diesel fuel at \$4/gal

## SPECIFICATIONS

<b>Performance Output</b>	12 Volts 240 Amps (160 Amps at idle) 12 Volts 275 Amps (180 Amps at idle) 12 Volts 300 Amps (190 Amps at idle) 12 Volts 320 Amps (190 Amps at idle)
<b>Maximum Speed</b>	8,000 RPM Continuous, 10,000 RPM Intermittent
<b>Rotation</b>	Clockwise
<b>Temperature Rating</b>	240 & 275 Amp: 125°C/257°F 300 & 320 Amp: 115°C/239°F
<b>Mounting</b>	J180 Short Hinge Mount, J180 Long Hinge Mount, Pad Mount
<b>Efficiency</b>	72%
<b>Weight</b>	31 lbs/14.1 kg

[delcoremy.com](http://delcoremy.com)



®



13975 BorgWarner Drive  
Noblesville, IN 46060 USA  
For Customer Service or Technical Assistance call 1-800-372-3555

Delco Remy is a registered trademark of General Motors Corporation licensed to BorgWarner PDS (Anderson) L.L.C. | C11127 | 6-19

GENUINE PRODUCTS

AVAILABLE THROUGH:

**KIRKS** TRANSIT FLEET EQUIPMENT  
YOUR PARTNER FOR PARTS SINCE 1946  
800.321.5989 | [KIRKS.com](http://KIRKS.com)

# 40SI™ Heavy Duty Brushless Alternator

Raising the bar for high output alternators

## COMPETITIVE COMPARISON

Specs	40SI	Leece Neville
<b>Design</b>	Brushless	Brush
<b>Temp. Rating</b>	240 & 275 Amp: 257°F/125°C 300 & 320 Amp: 239°F/115°C	230°F/110°C
<b>Average Efficiency</b>	72%	60%
<b>Weight</b>	31 lbs/14.1 kg	32 lbs/14.4 kg
<b>Stator Diameter</b>	152 mm	167 mm
<b>Length</b>	252 mm	272 mm
<b>Remote Sense</b>	Yes	No

## 40SI 12V POWER CURVE

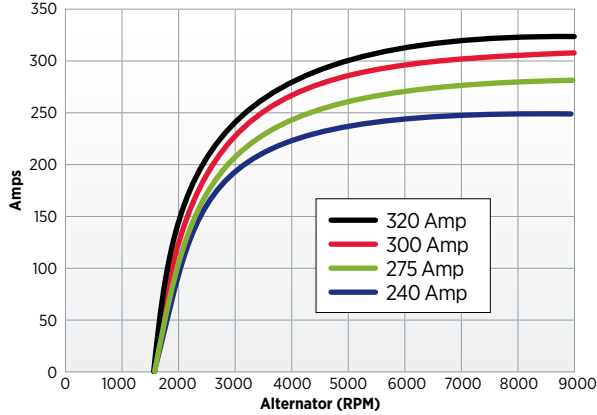

## INSTALLATION

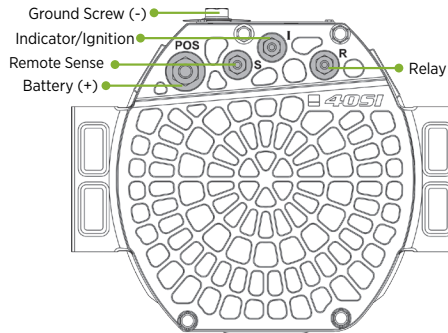

NOTE: When the Remote Sense terminal is not connected, the alternator operates and regulates voltage normally.

## COMPETITIVE INTERCHANGE DATA

40SI 12 VOLT						
Mounting	Delco Remy 40SI		Leece-Neville			
	Part #	Output (Amps)	Part #	Sales #	Output (Amps)	
Pad	8600338	240	BLP2332GH	BLP2332GH	185	
			BLP2334GH	BLP2334GH		
			A0014940PA	4940PA	200	
			A0014948PA	4948PA		
			A00149551PGH	4951PGH	220	
			A0014958PA	4958PA		
	8600094	275	A0014959PA	4959PA	270	
			A0014942PA	4942PA		
			A0014944PA	4944PA		
			A0014947PA	4947PA		
			A0014949PA	4949PA		
			A0014949GH	4949GH		
8600298	300	A0014975PAA	4975PAA			
J180 Long Hinge	8600628	320	A0014962PA	4962PA	320	
			A0014962PAH	4962PAH		
			A0014966PAA	4966PAA		
			A0014850AA	4850AA	200	
			A0014860AA	4860AA		
			A0014860JB	4860JB	220	
	A0014861JB	4861JB				
	8600390	240	A0014863JB	4863JB	240	
			A0014868JGH	4868JGH		
			A0014884JB	4884JB	245	
			A0014885JB	4885JB		
			A0014887JB	4887JB	250	
A0014852AA			4852AA			
A0014869JB			4869JB	270		
A0014873JB			4873JB			
8600280			275	A0014854AA	4854AA	320
				A0014856AA	4856AA	
				A0014867JB	4867JB	
				A0014867JGH	4867JGH	
	A0014870AA	4870AA				
	A0014870JB	4870JB				
8600300	300	A0014871JB	4871JB	320		
		A0014872AA	4872AA			
		A0014872JB	4872JB			
		A0014890AA	4890AA	320		
		A0014890JB	4860JB			
		A0014892AA	4892AA			
J180 Short Hinge	8600339	240				
	8600279	275				
	8600299	300				
40SI 24 VOLT						
Mounting	Delco Remy 40SI		Competitive Part Number			
	Part #	Output (Amps)				
J180 Short Hinge	61000853	160	BLD3315GH BLD3365GH ZLNBLD3365GH			
Pad	8600668	160	101210-9011, 110-816, 200619,20R0053, 272-1889, BLP3312, HDBSC150A			



13975 BorgWarner Drive  
Noblesville, IN 46060 USA  
For Customer Service or Technical Assistance call 1-800-372-3555

Delco Remy is a registered trademark of General Motors Corporation licensed to BorgWarner PDS (Anderson) L.L.C. | C11127 | 6-19

AVAILABLE THROUGH:



YOUR PARTNER FOR PARTS SINCE 1946

800.321.5989 | [KIRKS.com](http://KIRKS.com)

GENUINE PRODUCTS