

38MT™ Heavy Duty Gear Reduction Starter

FEATURES & BENEFITS

- **Available* with Integrated Over Crank Protection (IOCP)**, a built-in circuit breaker, protects the starter from thermal damage, automatically resetting at a safe operating temperature while eliminating the need for a wiring harness.
- **38MT+ features an Integral Magnetic Switch (IMS)**. IMS reduces voltage drop and ensures the solenoid receives the maximum available voltage in any starting condition.
- **Electrical soft-start** consistently and accurately engages the pinion with the ring gear providing increased reliability.
- **Warranty:** Non-OCP model: 1 year / unlimited miles
Integrated OCP model: 3 years / unlimited miles (Applicable to U.S. and Canada only)

* Part Number 8201084



COMPETITIVE COMPARISON

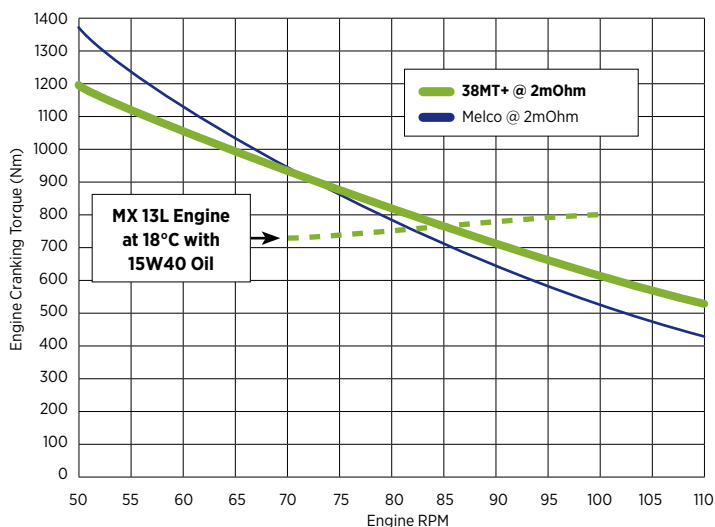

Cranks up to 4% faster than the competition



Integrated Over-Crank Protection (IOCP)

| Starter Model | OCP | Faster Cranking | Weight |
|------------------|----------|-----------------|------------------|
| Delco Remy 38MT+ | Optional | 82 Engine RPM | 28.44 lbs/12.9kg |
| Melco | No | 79 Engine RPM | 29.32lbs/13.3kg |

delcoremy.com



®



13975 BorgWarner Drive
Noblesville, IN 46060 USA
For Customer Service or Technical Assistance call 1-800-372-3555

Delco Remy is a registered trademark of General Motors Corporation licensed to BorgWarner PDS (Anderson) L.L.C. | C11127 | 6-19

AVAILABLE THROUGH:

KIRKS TRANSIT FLEET EQUIPMENT
YOUR PARTNER FOR PARTS SINCE 1946
800.321.5989 | **KIRKS.com**

GENUINE PRODUCTS

38MT™ Heavy Duty Gear Reduction Starter

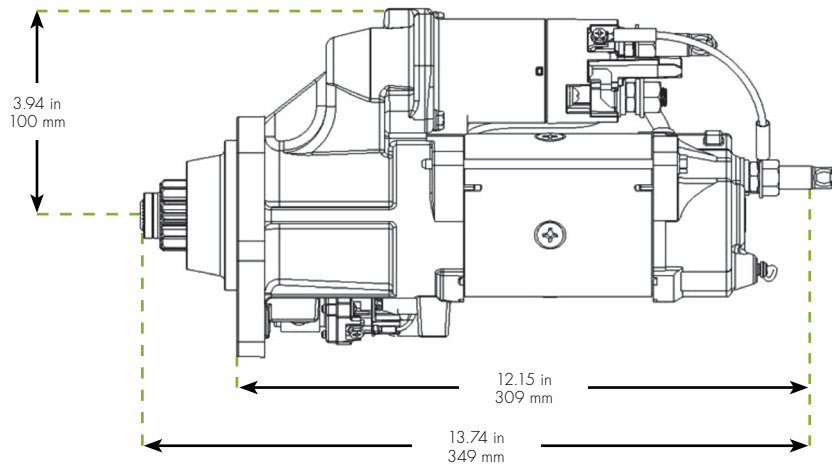

SPECIFICATIONS

| | |
|-------------------------|--------------------------------------------------------------|
| Engine Size | up to 13 liter |
| Rotation | Clockwise |
| Mounting | SAE #3 |
| Pinion Data | 12 Tooth, Mod 3-metric |
| Output | 4.3kW peak at 12V |
| Weight | 12.9 kg/28.44 lbs |
| Diameter | 100 mm/3.94 inches |
| Heavy Duty Drive | Electrical Soft-Start, Engagement System, Overrunning Clutch |

38MT+ designed to fit MX 11 and 13 liter engines

| OEM | Engine | Non-OCP 38MT+ | Integrated OCP 38MT+ | Teeth/Pinion/Pitch | Melco |
|--------|----------|----------------|----------------------|------------------------|-----------------------------------------------------------------------------|
| PACCAR | MX 11/13 | 8200977 | 8201084 | 12 Tooth, Mod 3 Metric | D61-1003-001 D61-6002-011 M009T72578 M9T72578 PC2578 1847916 |

Tech Support 800-372-3555

If you need assistance with part number identification or electrical system troubleshooting, we're here to help.

delcoremy.com



®



13975 BorgWarner Drive
Noblesville, IN 46060 USA
For Customer Service or Technical Assistance call 1-800-372-3555

Delco Remy is a registered trademark of General Motors Corporation licensed to BorgWarner PDS (Anderson) L.L.C. | C11127 | 6-19

AVAILABLE THROUGH:

KIRKS TRANSIT FLEET EQUIPMENT
YOUR PARTNER FOR PARTS SINCE 1946
800.321.5989 | **KIRKS.com**

GENUINE PRODUCTS