

35MT™ Heavy Duty Gear Reduction Starter



FEATURES & BENEFITS

- **High power density** allows more power in a smaller package
- **Patented Internal Magnetic Switch Solenoid (IMSS)** reduces corrosion and vibration issues while extending life
- **Electrical soft-start** consistently and accurately engages the pinion with the ring gear providing increased reliability
- **Compact design** minimizes packaging and simplifies installation
- **Warranty:** 1 year/unlimited miles (Applicable to U.S. and Canada only)

35MT 12V POWER CURVE

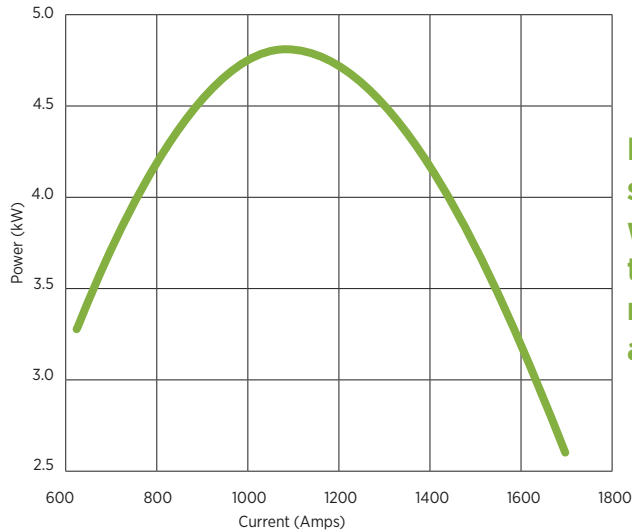

More power in a smaller package with patented technology to reduce corrosion and vibration issues

SPECIFICATIONS

Engine Size	up to 9 liter
Mounting	SAE #1, SAE #3
Rotation	Clockwise
Pinion	10 Tooth, 8-10 pitch; 12 Tooth, 8-10 pitch
Output Performance	12V peak at 4.7 kW
Temperature Rating	125°C/257°F
Weight	10 kg/22.04 lbs
Overall Length	355 mm/13.98 inches
Diameter	95 mm/3.74 inches
Motor Type	Wound Field, Planetary Gear
Engagement System	Electrical Soft Start
Pinion Support	Noseless

COMPETITIVE COMPARISON

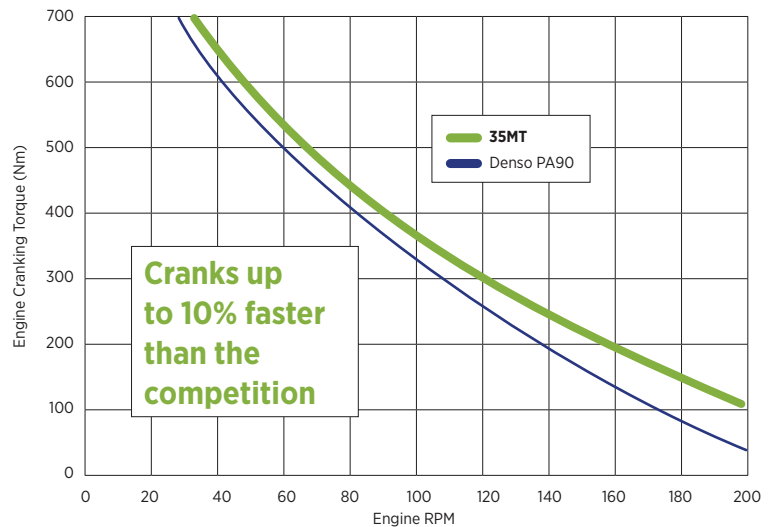

Cranks up to 10% faster than the competition

delcoremy.com



13975 BorgWarner Drive
Noblesville, IN 46060 USA
For Customer Service or Technical Assistance call 1-800-372-3555

GENUINE PRODUCTS

Delco Remy is a registered trademark of General Motors Corporation licensed to BorgWarner PDS (Anderson) L.L.C. | C11127 | 6-19

AVAILABLE THROUGH:

KIRKS TRANSIT FLEET EQUIPMENT
YOUR PARTNER FOR PARTS SINCE 1946
800.321.5989 | **KIRKS.com**

35MT™ Heavy Duty Gear Reduction Starter

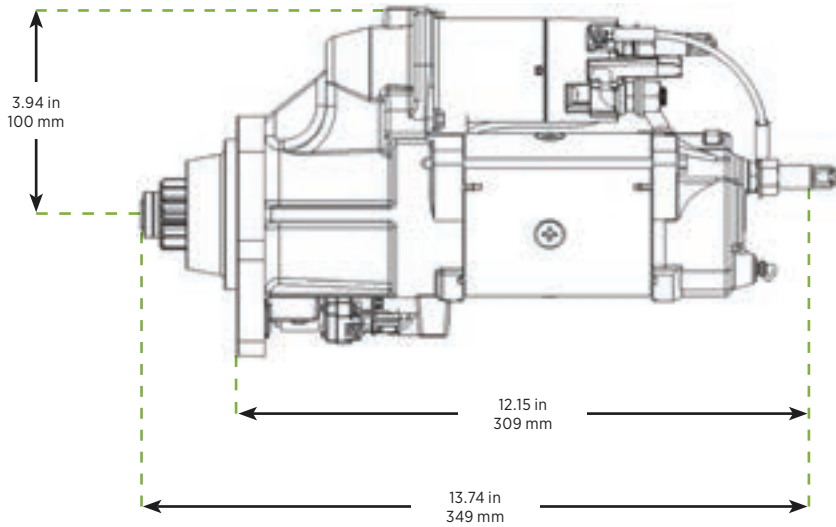

OEM	Engine	OE	Delco Remy All-Makes	Pinion Pitch/Teeth	Competitive Cross Reference	
					Leece Neville	Denso
Freightliner IC Bus Kenworth MCI Bus Navistar Peterbilt Sterling	Cummins ISC, ISL CAT C7, C9 DT 466	5267908 8200374 8200836	8200958	8/10 - 12 tooth	M105602 M105302 3700307C91	228000-8510 428000-1422 3601668C91
Freightliner Sterling Navistar Ford Truck	Cummins ISB	5267911 8200371 8200375 8200834	8200959	8/10 - 10 tooth	M105610	4996706 428000-7090

Tech Support 800-372-3555

If you need assistance with part number identification or electrical system troubleshooting, we're here to help.

delcoremy.com



GENUINE PRODUCTS



13975 BorgWarner Drive
Noblesville, IN 46060 USA
For Customer Service or Technical Assistance call 1-800-372-3555

Delco Remy is a registered trademark of General Motors Corporation licensed to BorgWarner PDS (Anderson) L.L.C. | C11127 | 6-19

AVAILABLE THROUGH:

KIRKS TRANSIT FLEET EQUIPMENT
YOUR PARTNER FOR PARTS SINCE 1946
800.321.5989 | KIRKS.com