

## Partner With Bison® To...

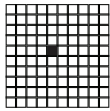

### Differentiate

... your bus, truck, off-road and rail equipment using the highest quality motors and pumps that provide heavy-duty, yet light weight and compact designs, CAN functionality, long life and much more.

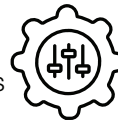

### Customize

... your vehicles' air- and other fluid-moving solutions, working side by side Bison® engineers who know the dynamics of fluid and have hundreds of years of cumulative experience.



### Save Time

... by running performance tests and rapid prototyping and more through a Bison® state-of-the-art engineering laboratory.



### Gain Access

... to heavy-duty transportation pumps and motors that are Buy America Compliant.

## Differentiate Your End Products With ROTRON® Pumps and Motors

- Brushless sealless pumps
- Brushless DC motors
- SAE J1939 CAN functionality
- Long life up to 60,000 hours
- Maintenance-free design



Bison® also manufactures a full line of brushless DC fans and impeller style blowers.

**Helping Fleet Owners....**



**Reduce**  
Operational Costs



**Eliminate**  
Downtime



**Increase**  
Service Time,  
Revenues & Profits

## Our Engineers Can Customize Your Air- and Other Fluid-Moving Solutions to...

- Heat and cool interiors
- Cool electronics, batteries & drive motors
- De-ice entryways
- Defrost windows
- And so much more!



LEARN MORE

**KIRKS** TRANSIT FLEET EQUIPMENT  
YOUR PARTNER FOR PARTS SINCE 1946

800.321.5989  
**KIRKS.com**

# 64 Frame

## Sealless Pump with Brushless DC Motor 60,000 Hour Design Life/26 Gallon

ROTRON®  
Transportation

### Pump

- Sealless design is leak proof; pump is magnetically coupled to motor
- Motor is removable from pump without draining system
- Environmentally resistant to hot-water spray, salt, fog, shock, and vibration
- Cast brass pump designed for heavy-duty applications

### Motor

- 24 VDC model only
- Motor design provides for maintenance-free operation by eliminating brush motor failures and brush maintenance
- Rare-earth magnets provide high efficiency and low current draw
- "O" ring sealed for harsh operating environment
- Reverse polarity and surge protected
- Heavy-duty construction required for transit bus and construction equipment



### Performance

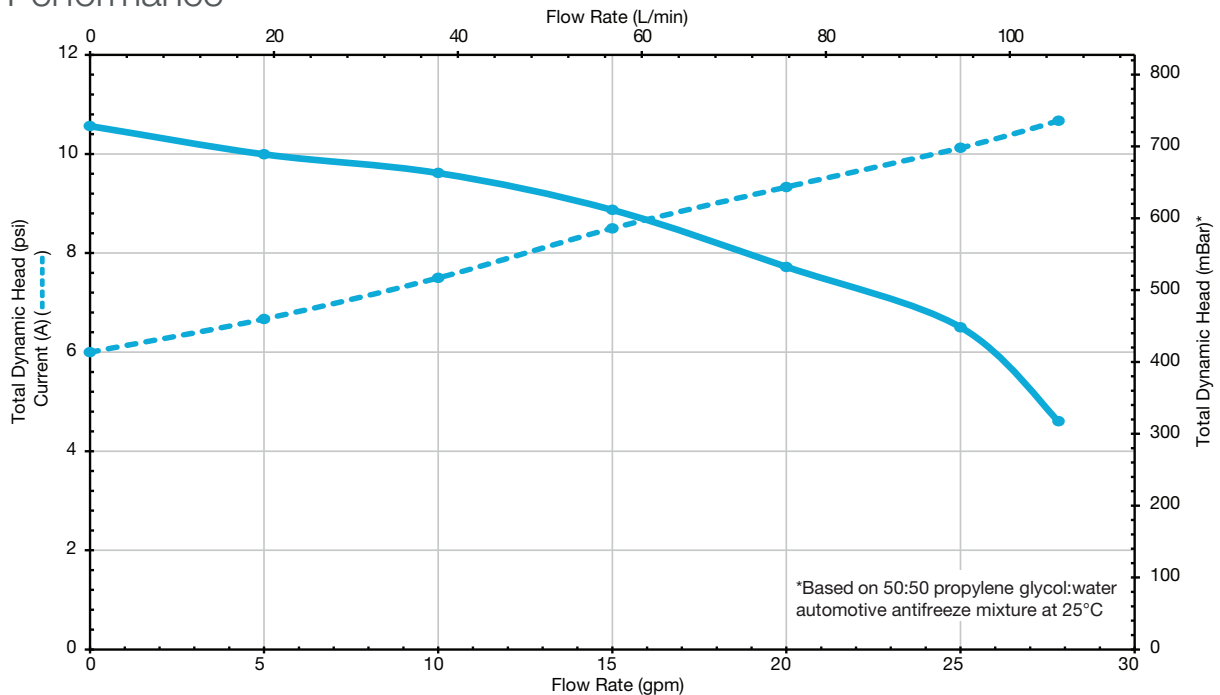

# 64 Frame



## Sealless Pump with Brushless DC Motor 60,000 Hour Design Life/26 Gallon

ROTRON®  
Transportation

### Typical Dimensions

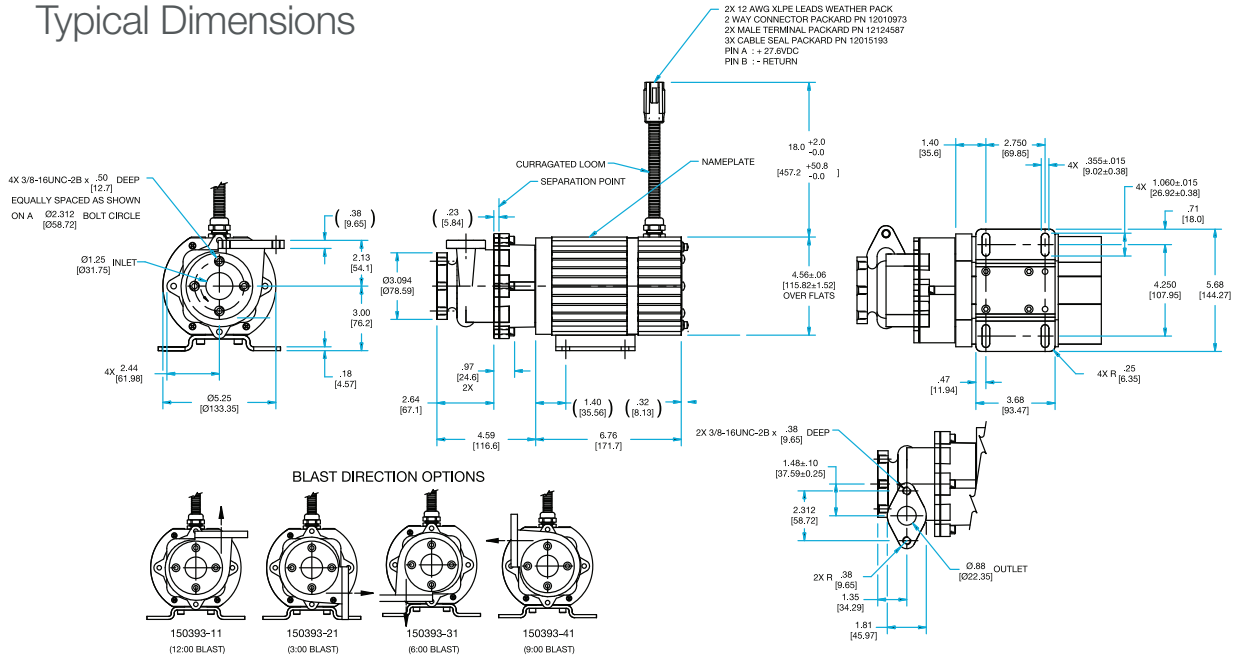

#### BLAST DIRECTION OPTIONS

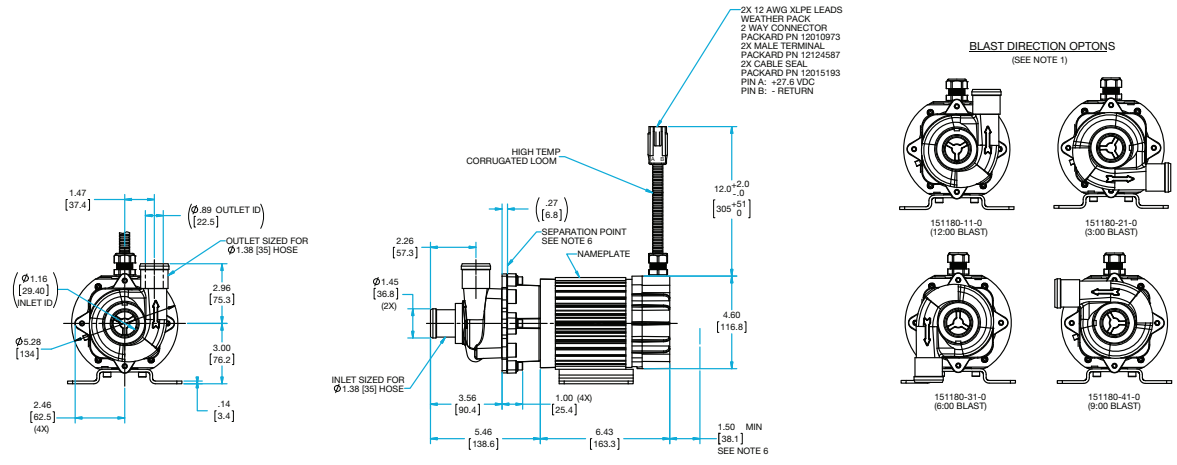
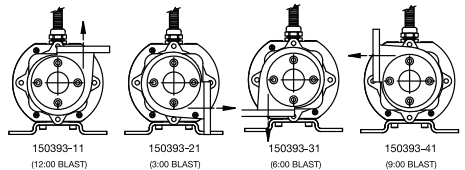

#### NOMINAL RATINGS

- VOLTAGE: 27.6 VDC
- VOLTAGE (INTERMITTENT): 18-32 VDC
- VOLTAGE (ABSOLUTE MIN): 11.0 VDC
- FLOW: 21 GPM @ 9.0 PSI
- MAX AMBIENT TEMP: +72°C
- CURRENT: 9.0 AMPS
- WEIGHT: 18.0 LB (APPROX)

- Motor design characteristics are based on an operating environment of 85°C.
  - Approximate typical weight: 25.0 lbs.
- This document is for informational purposes only and should not be considered as a binding description of the products or their performance in all applications. Actual performance will vary depending on the operating environment and application.



LEARN MORE

**KIRKS** TRANSIT FLEET EQUIPMENT  
YOUR PARTNER FOR PARTS SINCE 1946

800.321.5989  
**KIRKS.com**

# 100

## About **Bison®**

For more than 100 years, Bison® has helped customers differentiate their products by developing robust, flexible and durable motors, blowers and pumps under the brand names - Bison® Gearmotors, Lamb®, Nautilair®, Prestolite Motors, ROTRON® Regenerative Blowers, ROTRON® Transportation and Windjammer®.

Bison® engineers thrive on technical challenges and provide customers collaborative, customizable and optimized fluid-moving, fractional and integral horsepower solutions. Bison® has worldwide sales representative support, research facilities and manufacturing facilities in the United States, China and Mexico. The company is headquartered in Kent, Ohio.

---

*Bison® is a business of AMETEK, Inc. — a leading global provider of industrial technology solutions serving a diverse set of attractive niche markets with annual sales over \$6.0 billion.*

## About **ROTRON® Transportation Pumps and Motors**

# 75

For more than 75 years, Bison® has designed and manufactured **ROTRON®** brushless sealless pumps and brushless DC motors for heavy-duty transportation OEMs building trucks, buses, locomotives, light rail equipment, off-road vehicles and more.

Our ROTRON® transportation products offer long life up to 60,000 hours, CAN J1939 functionality and maintenance-free designs. The fluid-moving technologies can be customized to OEM specs and are **Buy America Compliant**.



© 2023 AMETEK, Inc. All rights reserved.



800.321.5989  
**KIRKS.com**